

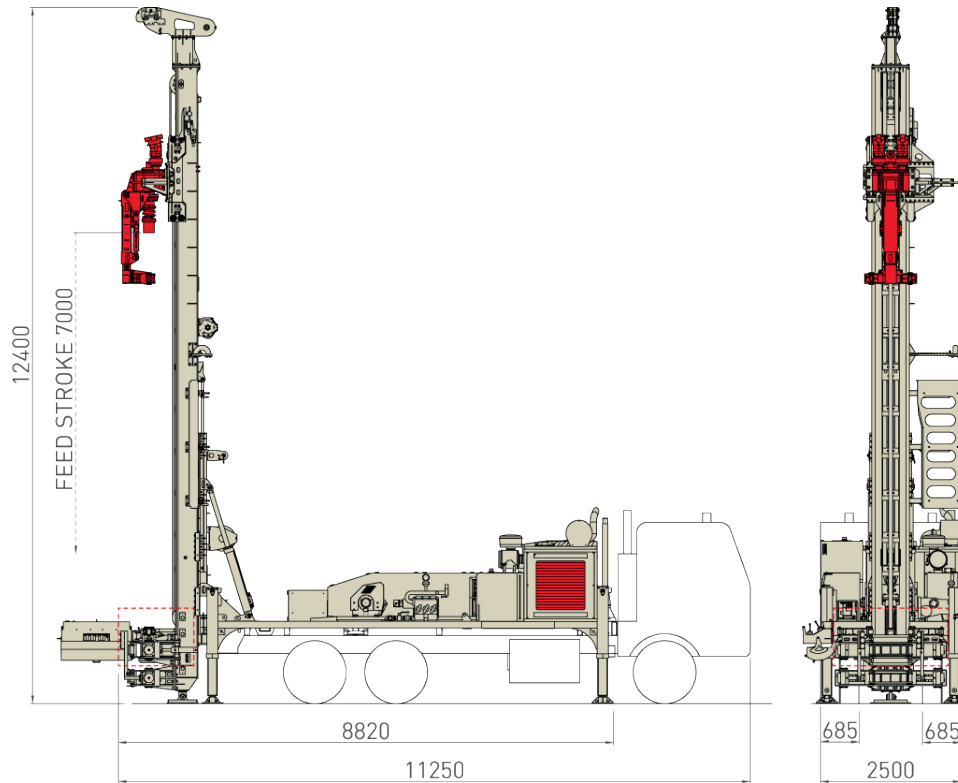

MC-T 20



	m.s.	i.s.		
Camion (assi)	-	-	(6x6 - 8x4 - 8x6) 3/4	
Podwozie (osie)	-	-		
Potenza Motore	kW	HP	205 - 245	278 - 333
Moc silnika				
Livello Emissioni	-	-	Step 3A/Tier3 - Step 5/Tier 4f (HT line)	
Poziom emisji spaliny				
Corsa Mast	mm	ft	7.000	22.9
Skok posuwu maszty				
Forza di Spinta	daN	lbs	12.000	26,977
Siła nacisku				
Forza di Tiro	daN	lbs	20.000	44,962
Siła wyciągania				
Coppia Rotary	daNm	lb*ft	2.300 - 3.750	16,963 - 27,658
Zakres momentu obr.				
Giri Rotary	rpm		110 - 180	
Zakres prędkości obr.				
Serraggio Morse	mm	in	45 - 520	1.8 - 20.4
Zakres pracy zacisków				
Argano	kg	lbs	2.000 - 5.700	4,400 - 12,600
Wciągarka				
Peso Perforatrice	kg	lbs	13.000 - 18.000	28,600 - 39,700
Masa wierownicy				

