

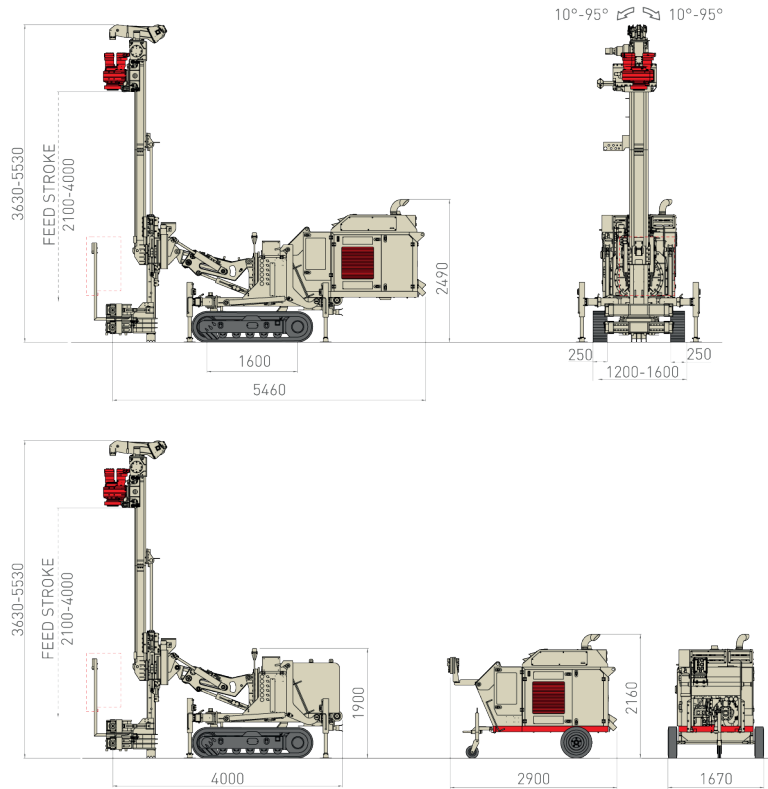

# MC 8D



głowica pojedyncza      głowica pojedyncza



Rotazione  
Wiercenie obrotowe



Rotopercussione  
Obrotowo-uderzowe

	m.s.	i.s.		
Potenza Motore <i>Moc silnika</i>	kW	HP	97	130
Livello Emissioni <i>Poziom emisji spalini</i>	Step 4 / Tier 4f (HT Line)			
Motore Elettrico <i>Silnik elektryczny</i>	kW		75	
Corsa Mast <i>Skok posuwu maszty</i>	mm	ft	950 - 4.000	3.1 - 13.1
Forza di Spinta <i>Siła nacisku</i>	daN	lbs	5.500	12,364
Forza di Tiro <i>Siła wyciągania</i>	daN	lbs	5.500	12,364
Coppia Rotary <i>Zakres momentu obr.</i>	daNm	lb*ft	450 - 2.325	3,319 - 17,148
Giri Rotary <i>Zakres prędkości obr.</i>	rpm		70 - 380	
Serraggio Morse <i>Zakres pracy zacisków</i>	mm	in	45 - 360	1.8 - 14.2
Peso Perforatrice <i>Masa wiertnicy</i>	kg	lbs	9.100 - 9.600	20,000 - 21,000

