

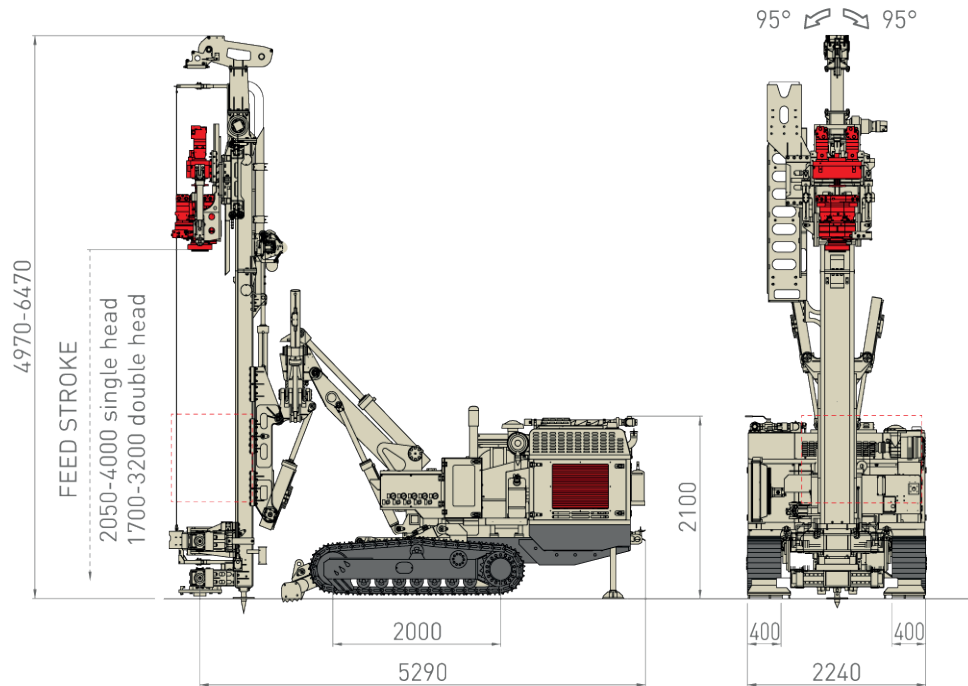

MC 14



	m.s.	i.s.		
Potenza Motore <i>Moc silnika</i>	kW	HP	129	173
Step 4 / Tier 4f (HT Line)				
Livello Emissioni <i>Poziom emisji spalin</i>	-			
Corsa Mast <i>Skok posuwu masztu</i>	mm	ft	1.700 - 4.000	5.6 - 13.1
Forza di Spinta <i>Siła nacisku</i>	daN	lbs	5.500	12,364
Forza di Tiro <i>Siła wyciągania</i>	daN	lbs	5.500	12,364
Coppia Rotary <i>Zakres momentu obr.</i>	daNm	lb*ft	1.000 - 2.325	7,375 - 17,148
Giri Rotary <i>Zakres prędkości obr.</i>	rpm		80 - 290	
Serraggio Morse <i>Zakres pracy zacisków</i>	mm	in	45 - 360	1.8 - 14.2
Peso Perforatrice <i>Masa wiertnicy</i>	kg	lbs	13.000 - 15.000	28,700 - 33,100

